



**GlobalLux**  
LIGHTING

LED Center Basket  
LCB Series





# High Performance Design Can Customize To Your Environment

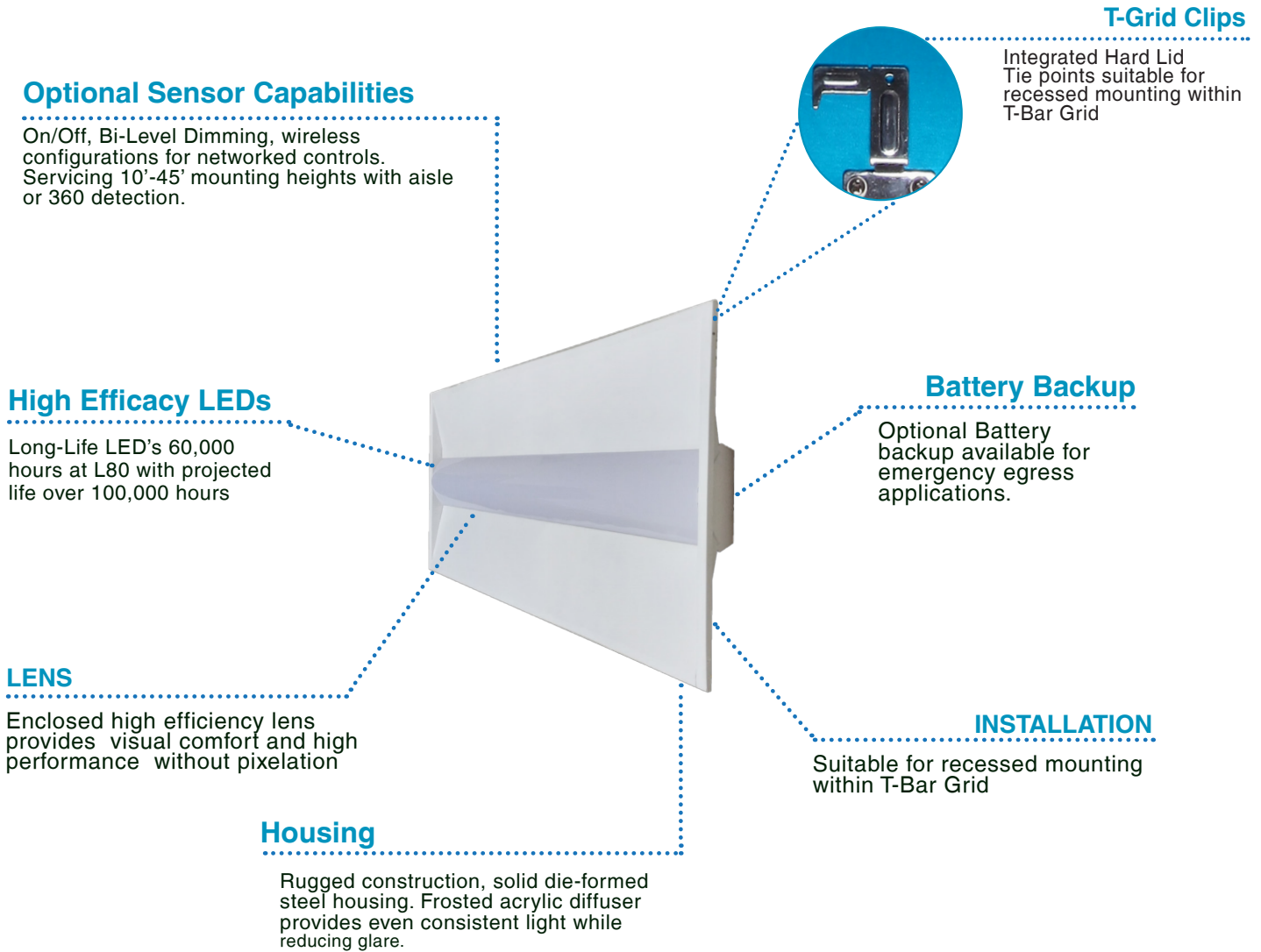

## LCB Wattage Comparison

	GlobalLux LIGHTING	Conventional Fluorescent
Hospitals, warehouse facilities, office, schools Size: 2x4	40W 5,000 Lumens	3-4 Lamps T8 96W-128W
Hospitals, warehouse facilities, office, schools Size: 2x2	30W 3,750 Lumens	2 Lamps T8 51W-64W

# Ordering Information

## Dimensions

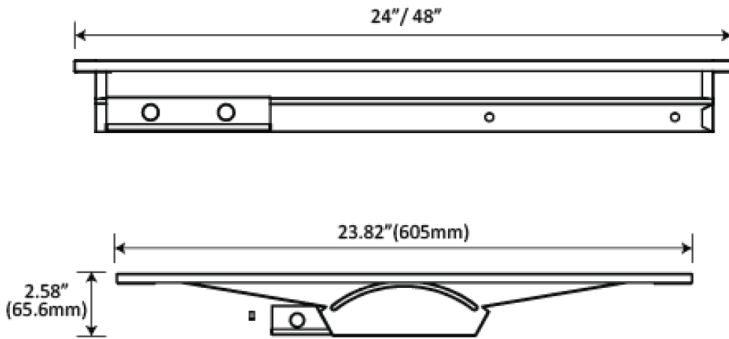

## Specification Features



### Construction

Rugged construction, solid die formed, cold-rolled steel housing. All fixture surfaces powder coated after fabrication. Frosted acrylic diffuser provides even consistent light while reducing glare. Lens design and materials provide uniform appearance without pixelation.

### Qualifications

All luminaires are built to UL 1598 and 2108 standards, and bear appropriate ETL labels. Wet location labeling is standard. Emergency equipped fixtures labeled UL924. Adheres to LM70, LM80, and TM21 industry standards. DesignLights Consortium® (DLC) Premium qualified product. Not all product variations are DLC Qualified. Please visit list at [www.designlights.org/QPL](http://www.designlights.org/QPL) to confirm which models are qualified.

### Electrical

Equipped standard with 0-10V continuous dimming driver that works with any standard 0-10V control/dimmer. Long-Life LED's 60,000 hours at L80 with projected life over 100,000 hours for reduced life cycle maintenance costs.

### Installation

Suitable for recessed mounting within T-Bar grid.

### Warranty

5-year Limited Warranty. See warranty documentation for more information.

### Options

Optional On/Off or Bi-Level motion sensor, high voltage transformers, emergency battery backups, whips and cords.

### LCB Series

#### 2x2 Housing

30W 3900 Lumens

#### 2x4 Housing

40W 5200 Lumens

Rated Life 60,000 hours  
Limited Warranty 5 years  
Efficacy Up to 130 LPW  
Continuous Dimming



### Quick Ship/ DLC Listed

- LCB-22-30-MVD-835
- LCB-22-30-MVD-840
- LCB-22-30-MVD-850
- LCB-24-40-MVD-835
- LCB-24-40-MVD-840
- LCB-24-40-MVD-850

## Ordering Information

Example: LCB-22-30-MVD-835

LCB	22	30	MVD	8	40	
<b>Series</b> LCB Recessed LED center Troffer	<b>Form Factor</b> 22- 2'x2' <sup>2</sup> 24- 2'x4' <sup>2</sup>	<b>Rated Wattage</b> <u>2x2 Housing</u> 30-30W 3900 Lumens <sup>2</sup> <u>2x4 Housing</u> 40-40W 5200 Lumens <sup>2</sup>	<b>Driver Type</b> MVD- 120-277V; 0-10V Dimming <sup>1</sup>	<b>CRI</b> 8 80+ CRI	<b>Color Temp</b> 35 3500 K 40 4000 K 50 5000 K	
<b>Options</b>						
		<b>Emergency Backup</b> EML8 800lm EML16 1600lm	<b>Accessories</b> CS6-183-183-BL- 6' Cord 18-3 TO 18-3 SJT ENDS Black Finish SMK-22- 2'x2' Surface Mount Kit SMK-24- 2'x4' Surface Mount Kit	<b>Mounting Accessories</b> FW3- 6FT Flex 18/3 FW4- 6FT Flex 18/4 FK-22- 2'x2' Flange Kit FK-24- 2'x4'- Flange Kit		

Specifications and Dimensions subject to change without notice.

<sup>1</sup> Made to order items. Minimum 90 day lead time. Minimum 500 order quantity.

<sup>2</sup> DLC Listed

# Adders Options & Accessories



### Integral Microwave Sensor, On/Off

An economical fixture mounted sensor utilizing passive infrared technology turns the fixture On/Off.

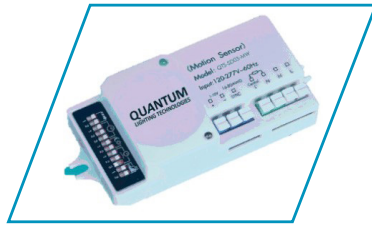

### Integral Bi-Level Microwave Sensor

Part of the Globalux family of Intelligent sensors that dims the fixture to either 10,20,30, or 50% of full light output for safety and code compliance, and automatically switches to full illumination when the space is occupied.

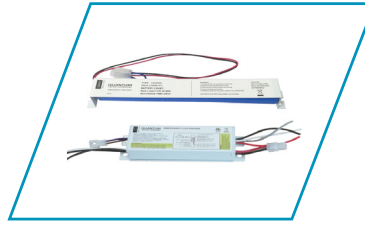

### Emergency Battery

The emergency battery back-up provides 90 minutes of power to your fixture in the event of an emergency.

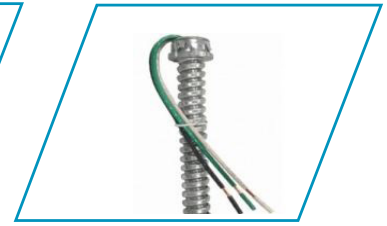

### Fixture Whips

Armored cable fixture whips used for lighting and power distribution.



### High Voltage Transformers

High voltage transformers allow the fixture to receive a higher power input of 347V-480V.



### Cords & Plug Option

Standard 6ft cord with custom lengths and plugs available for wiring fixture.



### Flange Kit

Flange mounting kit turns a recessed panel into a lay-in grid, overlapping flange, and swing-gate hanger mounted panel.

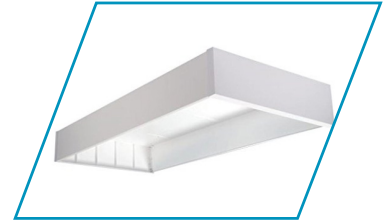

### Surface Mount Kit

Designed for quick and simple installation, this surface mount kit is specifically for use with LCB LED Troffers for ceiling mount.

## Cords, Plugs and Whips

FW3	3FT Flex 18/4
FW4	4FT Flex 18/4

## Voltage

MVD	120-277V; 0-10V Dimming
-----	-------------------------

## Emergency Battery Back-up

EML8	800 Lumen Emergency Battery
EML16	1600 Lumen Emergency Battery

## Motions Sensors

MOS	Integral Mic. Sensor On/Off
MOSB	Integral Mic. Sensor Bi-Level

## High Voltage

HVD	347-480V, 0-10V Dimming
-----	-------------------------

## Mounting

FK-22	2'x2' Flange Kit
FK-24	2'x4' Flange Kit